

MODEL IC10100

A highly efficient and strong performing ice and water dispenser machine, built with highly durable materials and with elegant and attractive design. Designed to complement high class premium food spaces

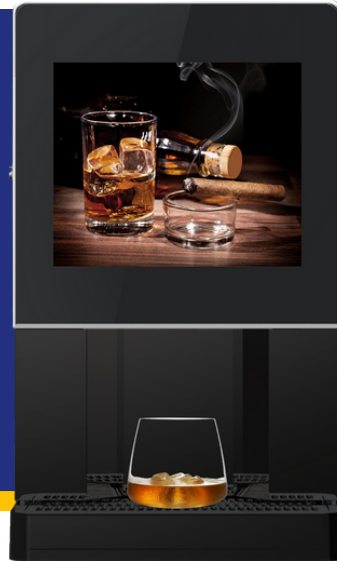

DESIGN & BUILD

AN ATTRACTIVE AND SUPERBLY BUILT ICE & WATER DISPENSER ALLOWING FOR HIGH VOLUME PRODUCTION WITH MINIMAL SPACE USEAGE.



STREAMLINED DESIGN

FULLY INTERACTIVE COLOUR DISPLAY ALLOWS FOR SUPER EASE, SELF SERVE AND ULTIMATE HYGIENE



USER FRIENDLY

FULLY AUTOMATIC AND USER INTUITIVE DESIGN. PERFECT FOR A FAST PACED ENVIRONMENT



ENERGY EFFICIENCY

HIGH PERFORMANCE WITH LOW ENERGY USE.



MODEL IC10100

A highly efficient and strong performing ice and water dispensing machine, built with highly durable and elegant materials and designed to complement premium food space designs.

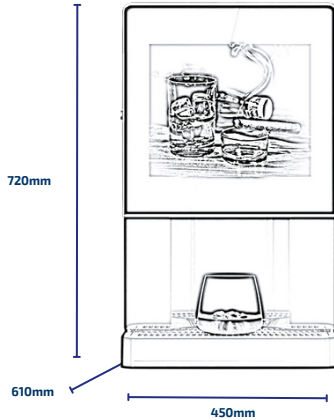

Design

Colours.....Black
Output Capacity.....100kg / 24hrs

Machine Type

Ice Output.....Cube / Nugget
Installation.....Counter Top / Built in

Weight

Net.....49kg

Dimensions

Machine Width.....450mm
Machine Depth.....610mm
Machine Height.....720mm

Electrical

Power Voltage.....220/ 110volt
Air cooling Power input watts.....850w

Specifications

- ✓ Dispenser Ice and Water
- ✓ Energy Efficiency & Eco friendly R290 refrigerants.
- ✓ Elegant and attractive styling with touch screen display
- ✓ Self Serve and hygienic design
- ✓ Self-contained bin store fresh ice
- ✓ Continuously replenished Touchscreen interface for hygiene-controlled dispensing
- ✓ Fully automatic and simply operate for easy access
- ✓ Energy efficient and drainless technology Ice can be set for different amount for dispensing
- ✓ Big production capacity in a small tabletop
- ✓ Perfect for fast-paced environment